

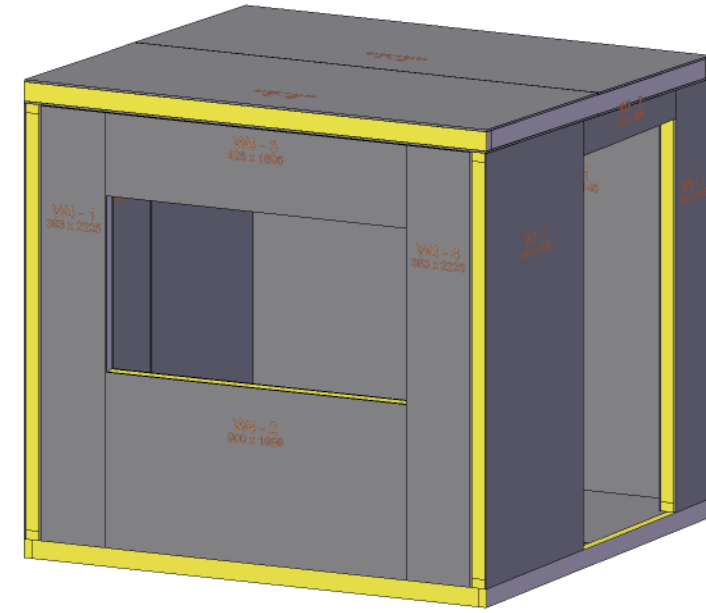

Plan

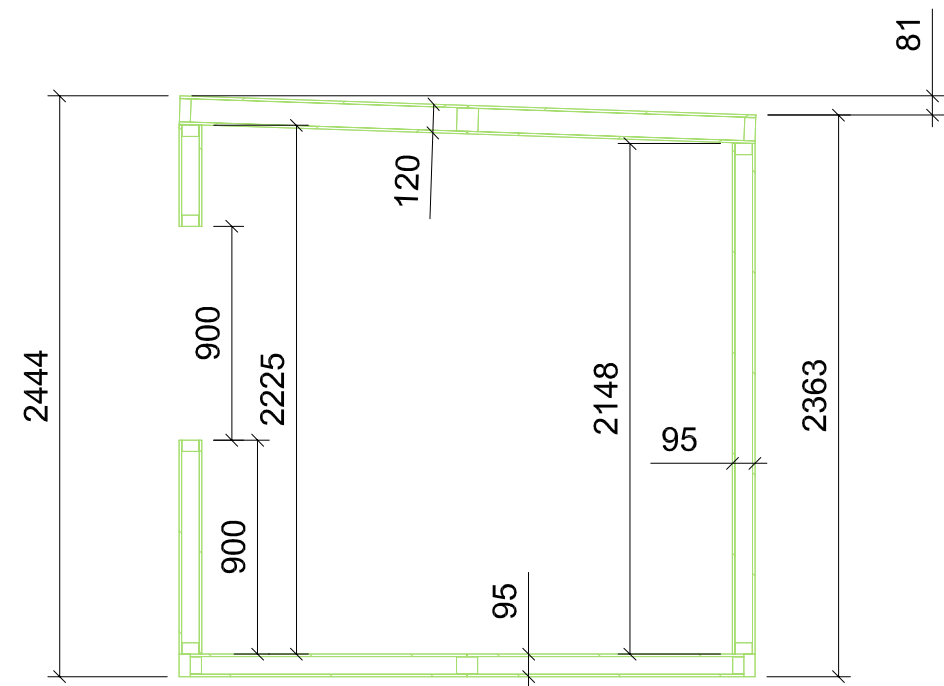

Iso



Sections

Style				Office Bloc 2.6 x 3.6	
Site Address :					
		SIPS UK Ltd		Scale :	
		Unit 1		NTS	
Sanders Lodge Ind. Est Wellingborough Road Rushden, Northants NN10 6BQ		Date:		Drawing Number :	
		23/01/2021		2.6 x 2.4	
		Title :		Rev :	
		Plan/Iso/Sections		0	

ANY DISCREPANCIES OR QUERIES TO BE CHECKED BEFORE PROCEEDING

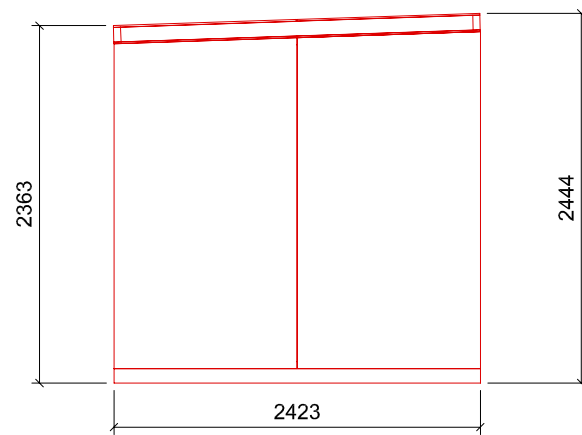

LH Elevation

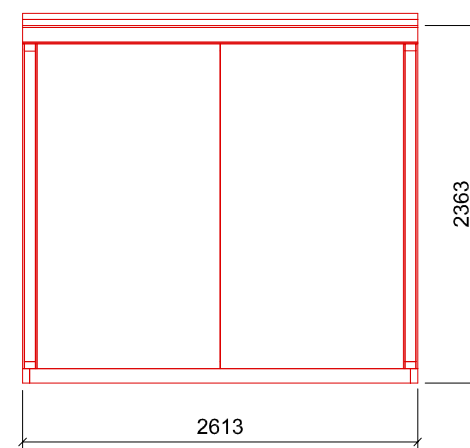

Rear Elevation

Opening dimensions are structural, we would recommend when purchasing windows that a minimum reduction of 5mm all round is taken of of these timensions

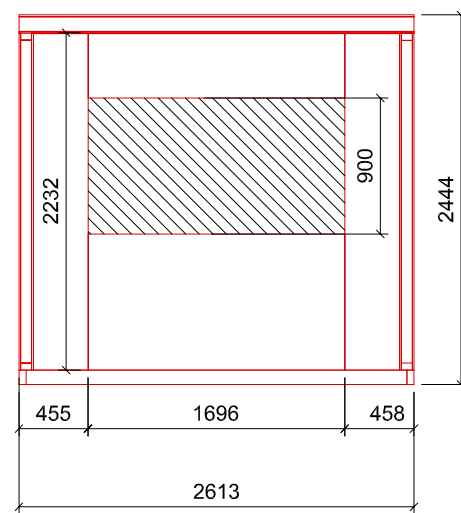

Font Elevation

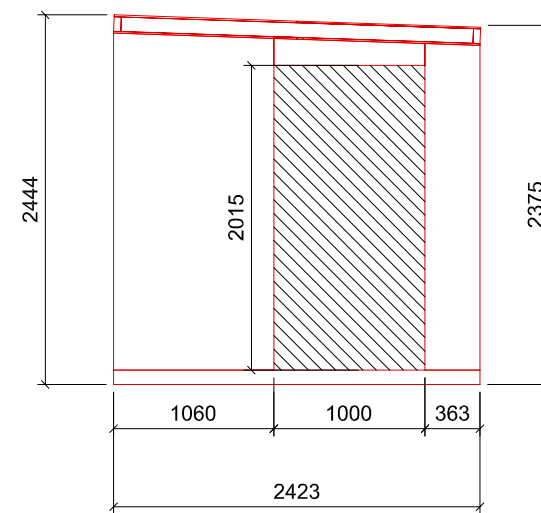

RH Elevation

Style		<b>Office Bloc 2.6 x 3.6</b>	
Site Address :			
Scale :		Drawing Number :	
NTS		2.6 x 2.4	
Drawn by :		NP	
Date :		Rev :	
23/01/2021		0	
Title :		Elevations	

**sips uk**  
 SIPS UK Ltd  
 Unit 1  
 Sanders Lodge Ind. Est  
 Wellingborough Road  
 Rushden, Northants  
 NN10 6BQ

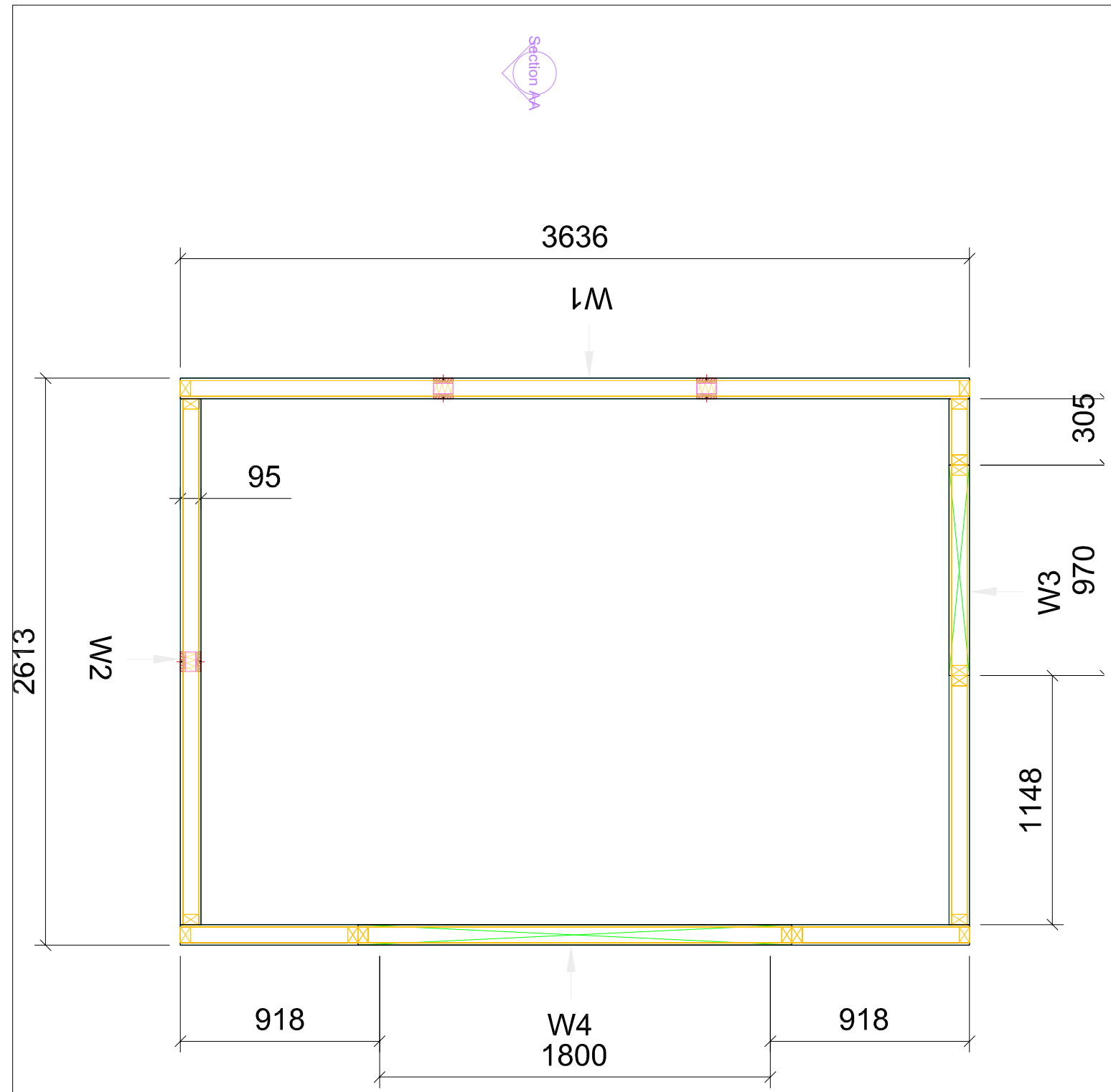

Plan

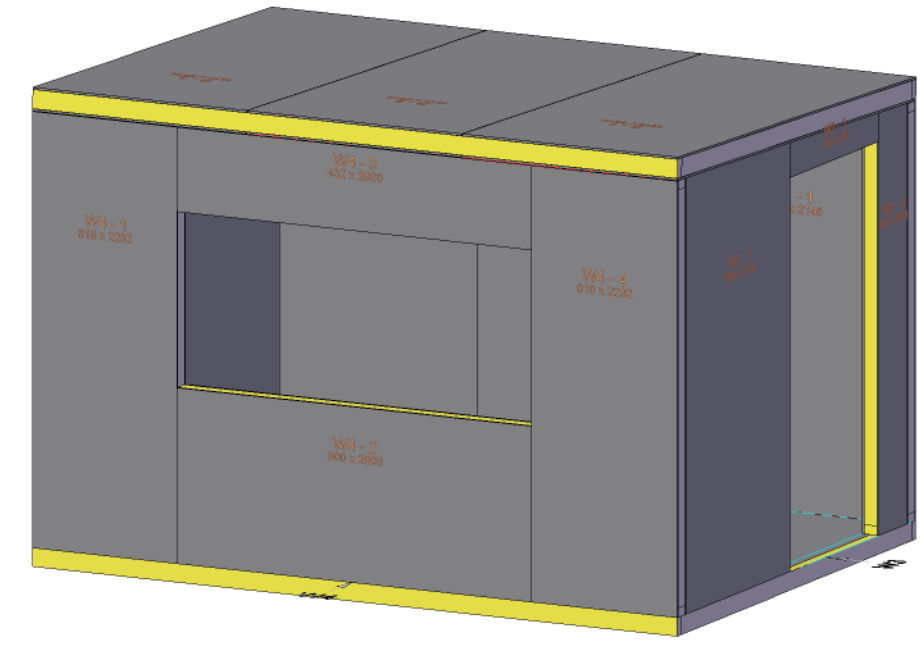

Iso

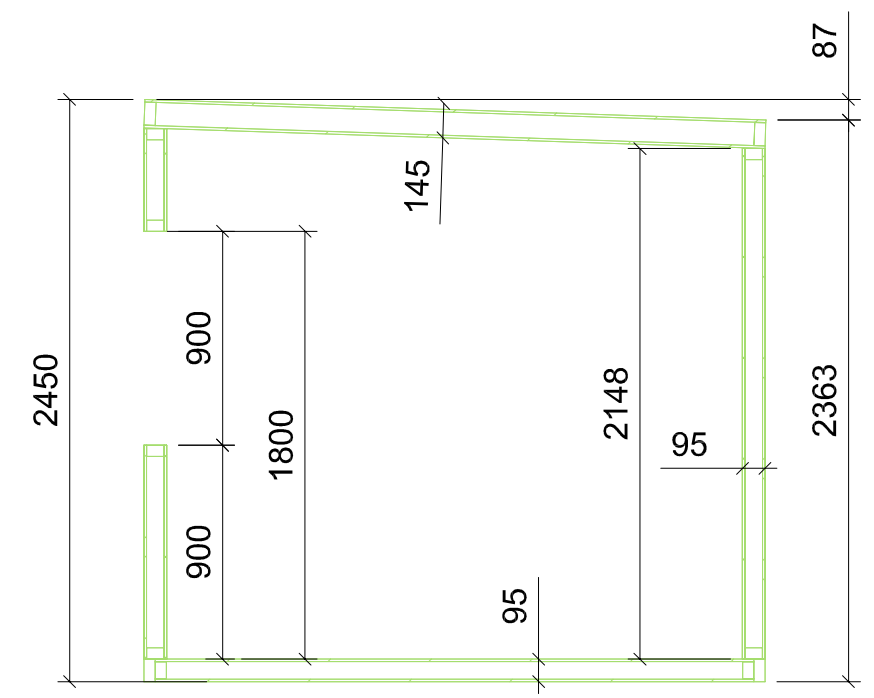

Sections

Style		Office Bloc 3.6 x 2.6	
Site Address :			
	SIPS UK Ltd Unit 1 Sanders Lodge Ind. Est Wellingborough Road Rushden, Northants NN10 6BQ		Scale : <b>NTS</b>
	Date: <b>23/01/2021</b>		Drawing Number : <b>3.6 x 2.6</b>
Title : <b>Plan/Iso/Sections</b>		Rev : <b>0</b>	

ANY DISCREPANCIES OR QUERIES TO BE CHECKED BEFORE PROCEEDING

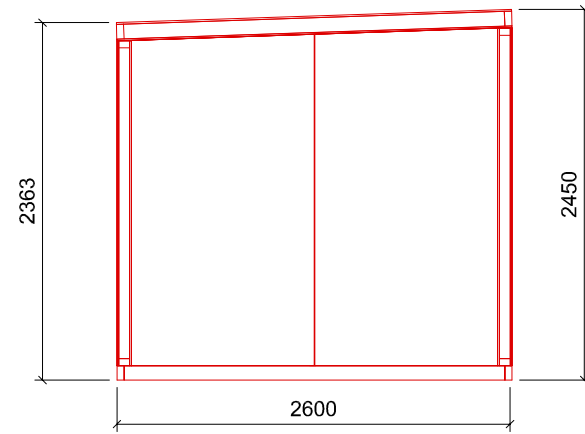

LH Elevation

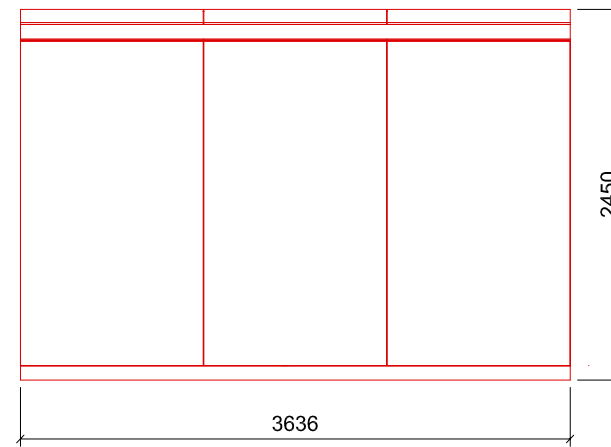

Rear Elevation

Opening dimensions are structural, we would recommend when purchasing windows that a minimum reduction of 5mm all round is taken of of these timensions

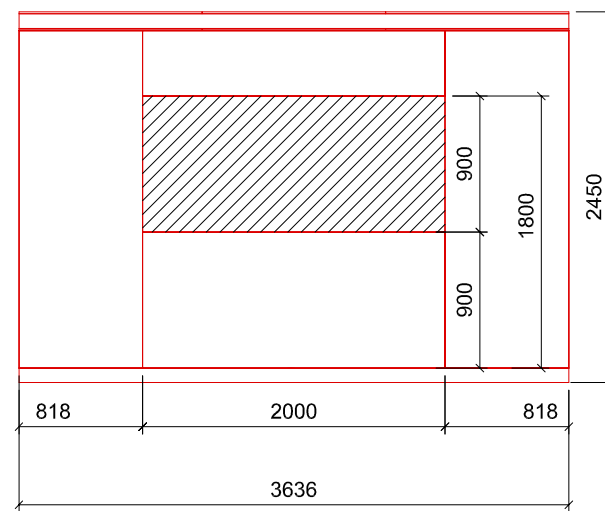

Font Elevation

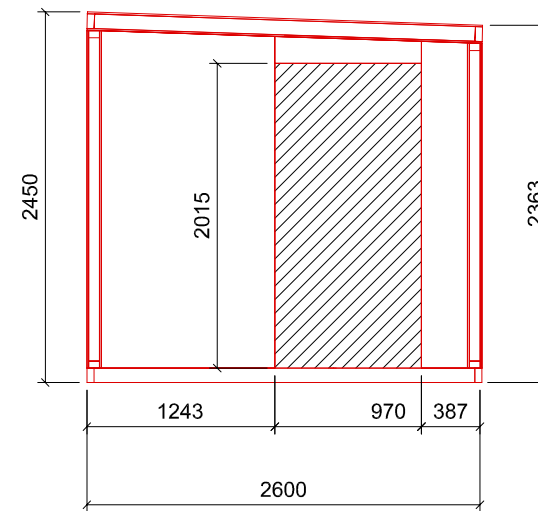

RH Elevation

Style		Office Bloc 3.6 x 2.6	
Site Address :			
Scale :		Drawing Number :	
NTS		3.6 x 2.6	
Drawn by :		Rev :	
NP		0	
Date :		Title :	
23/01/2021		Elevations	
 SIPS UK Ltd Unit 1 Sanders Lodge Ind. Est Wellingborough Road Rushden, Northants NN10 6BQ			
ANY DISCREPANCIES OR QUERIES TO BE CHECKED BEFORE PROCEEDING			

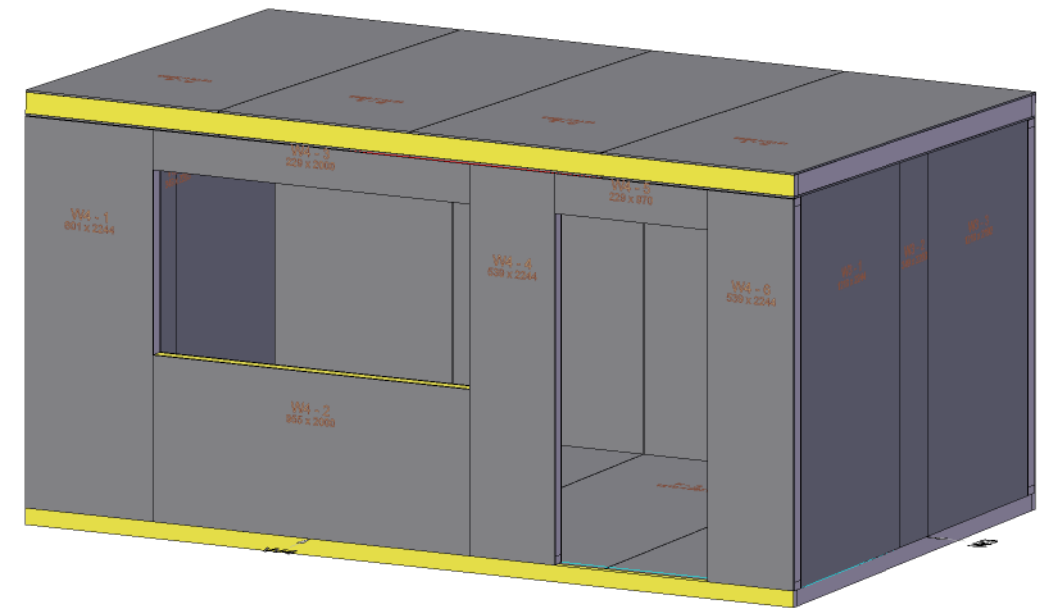
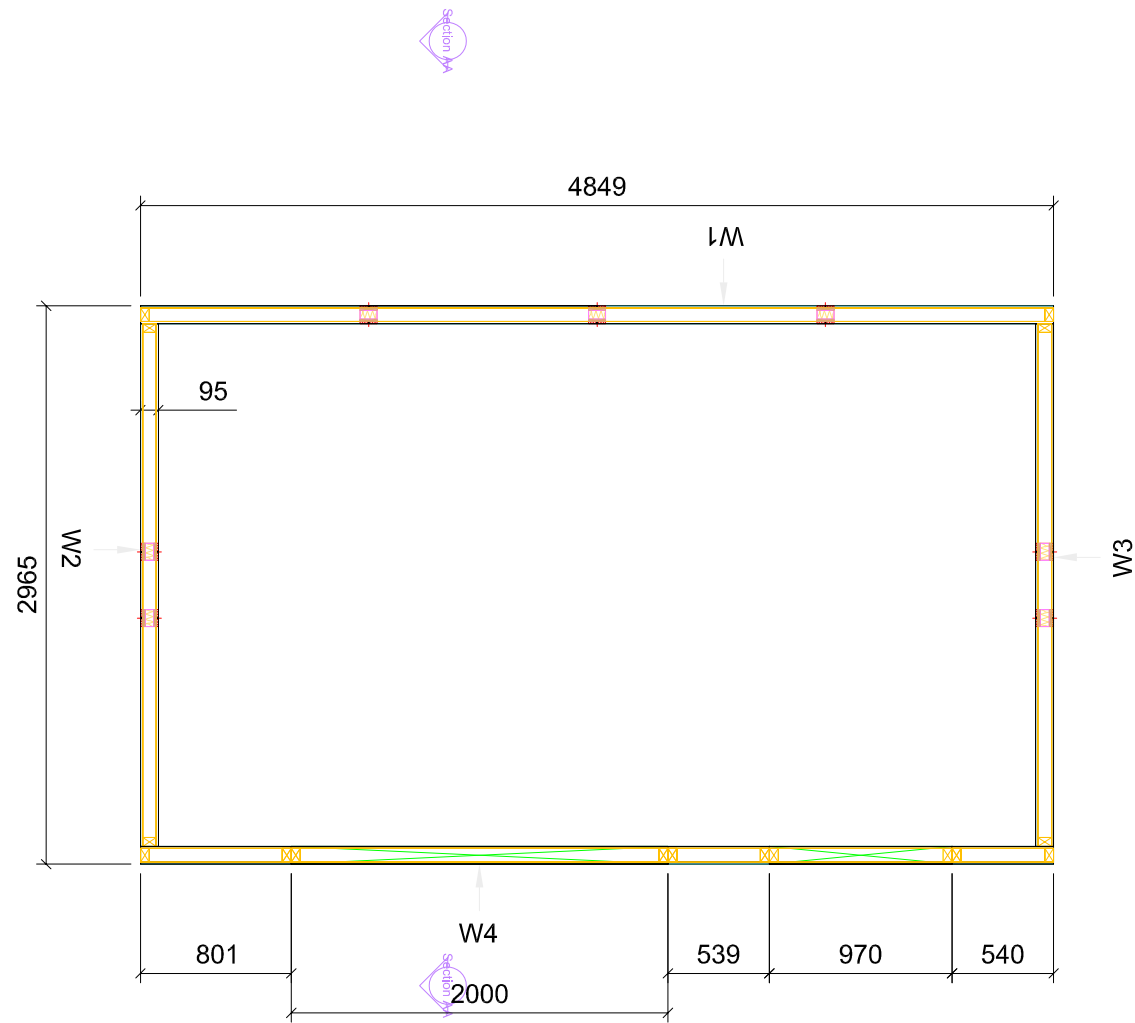

Iso

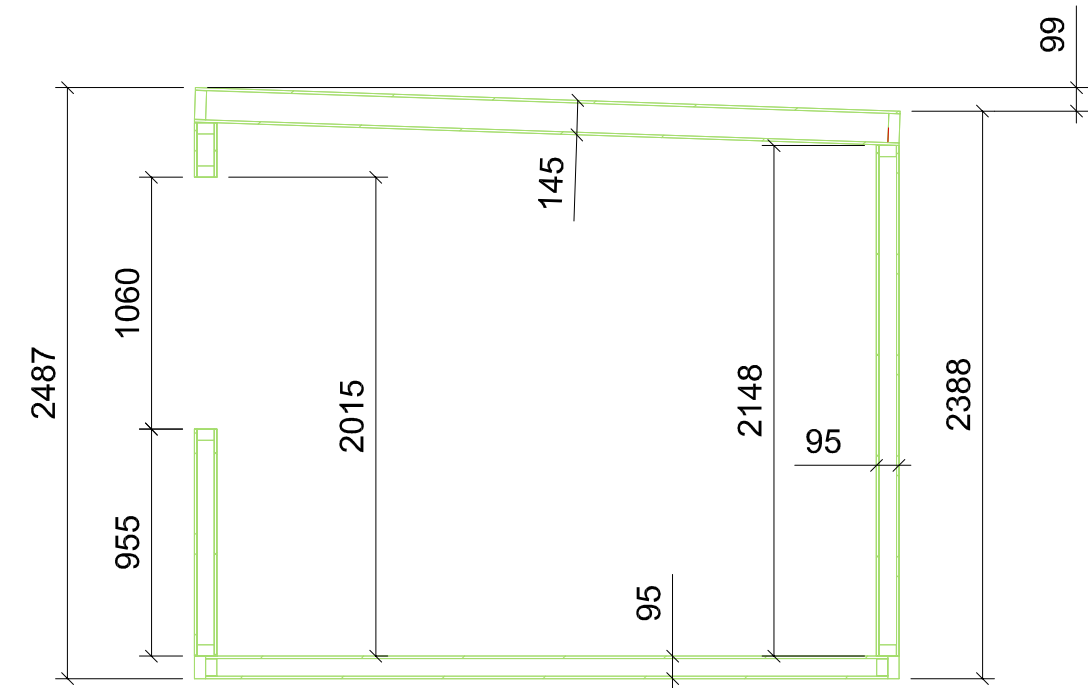

Sections

Plan

Style		Office Bloc 4.8 x 3	
Site Address :			
Scale :		Drawing Number :	
NTS		4.8 x 3	
Drawn by :		NP	
Date :		23/01/2021	
Title :		Plan/Iso/Sections	
SIPS UK Ltd Unit 1 Sanders Lodge Ind. Est Wellingborough Road Rushden, Northants NN10 6BQ		Rev : 0	
ANY DISCREPANCIES OR QUERIES TO BE CHECKED BEFORE PROCEEDING			

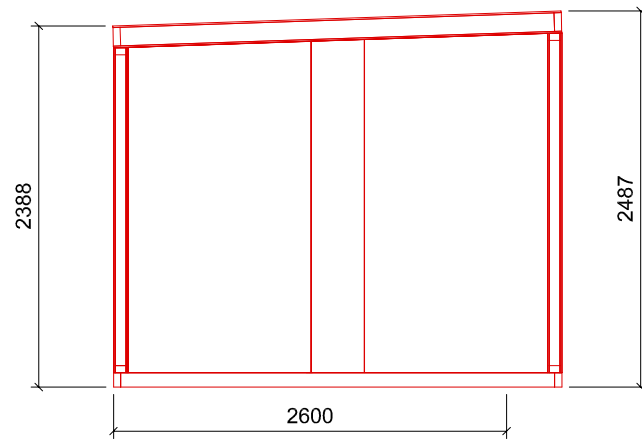

LH Elevation

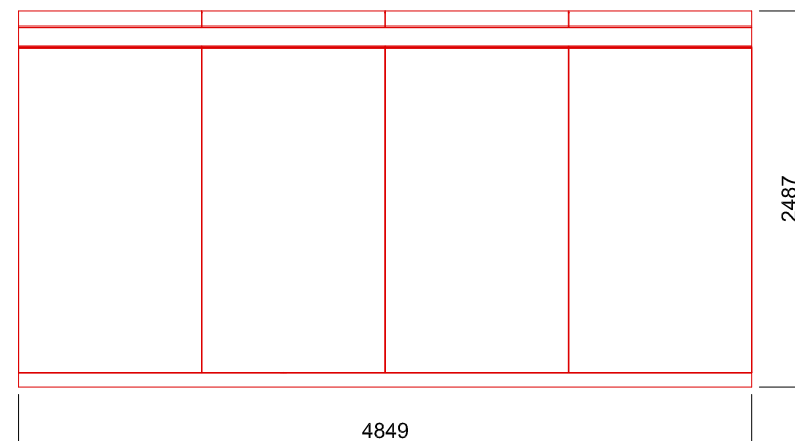

Rear Elevation

Opening dimensions are structural, we would recommend when purchasing windows that a minimum reduction of 5mm all round is taken of of these timensions

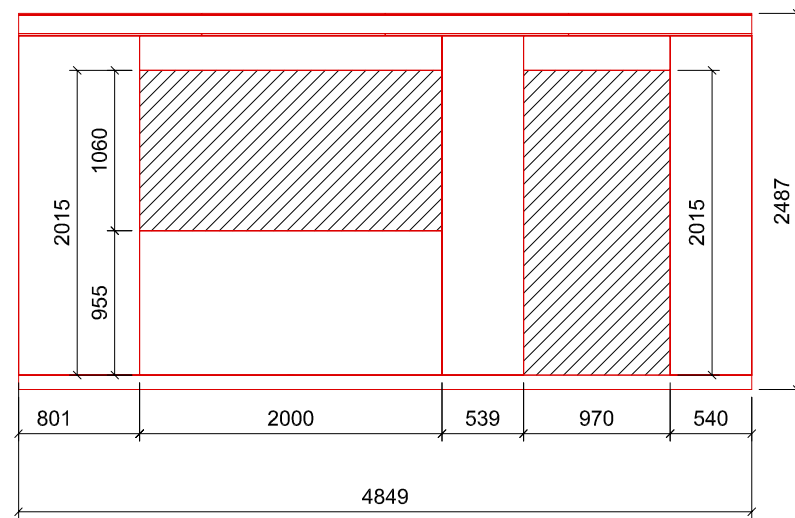

Font Elevation

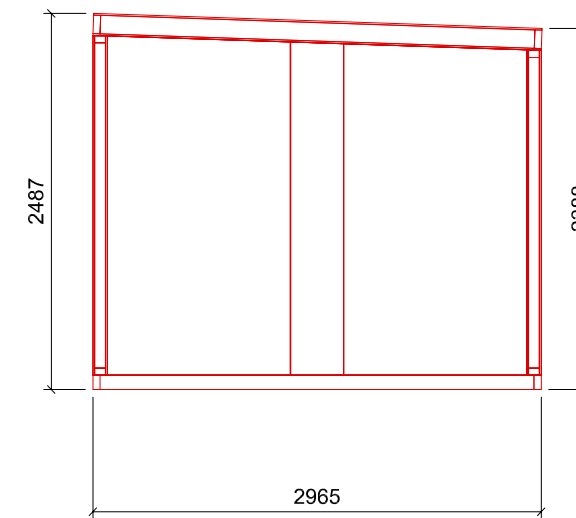

RH Elevation

Style		Office Bloc 4.8 x 3	
Site Address :			
Scale :		Drawing Number :	
NTS		4.8 x 3	
Drawn by :		NP	
Date :		23/01/2021	
Title :		Elevations	
SIPS UK Ltd Unit 1 Sanders Lodge Ind. Est Wellingborough Road Rushden, Northants NN10 6BQ		Rev : 0	
ANY DISCREPANCIES OR QUERIES TO BE CHECKED BEFORE PROCEEDING			